

SLEEVERS

WM/WS

High-Speed Wrap Around Sleevers

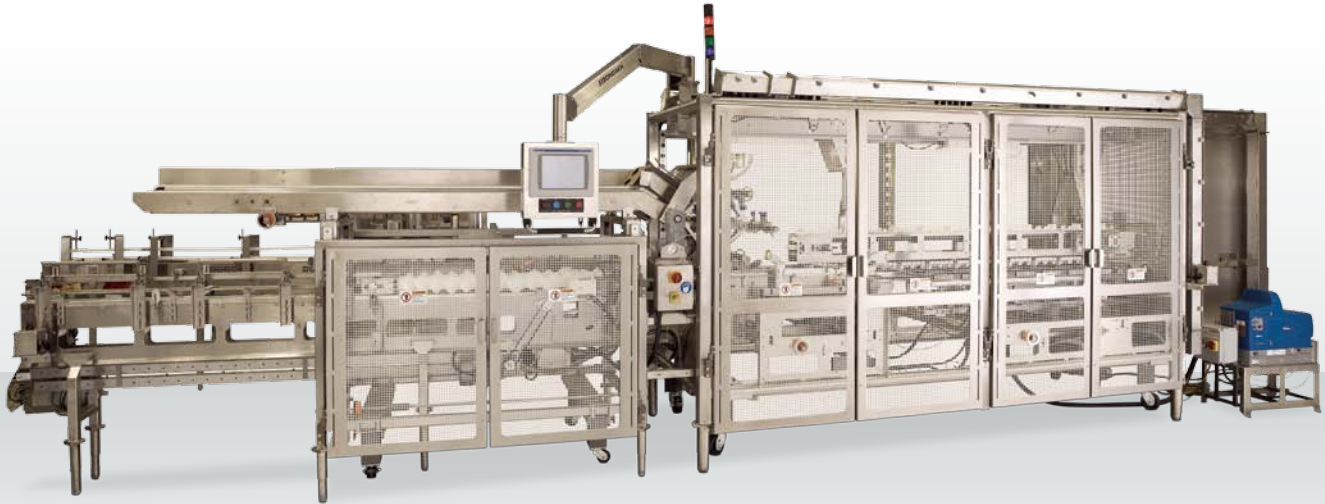

where products meet packaging™

When reliability, flexibility and performance matter, look no further than ADCO's family of rugged and dependable high-speed sleevers. Available in both, a mechanical version (WM) and a servo version (WS), ADCO's high-speed sleevers are the right solution for the most demanding production environments. Featuring class-topping speeds of up to 350 sleeves per minute, ADCO sleevers are capable performers with the ability to run a wide range of sleeve sizes and styles including neck-through and gusset sleeves. If you need to run multiple lanes, stack your products in layers or invert the top layer, ADCO's product handling experts are here to help. Like all ADCO machines, our wrap around sleevers are constructed in stainless steel and are available in standard or washdown configurations.

Benefits

- Stainless steel construction with sanitary design improves cleanability and eliminates corrosion
- High speed capability maximizes productivity and reduces machinery requirements
- Flexible and adaptable design protects your investment as products change
- Smooth continuous motion design and rotary feeder improve speed and efficiency
- Easy to load powered magazine reduces operator fatigue and increases run time
- Advanced guard design keeps operators safe and maximizes maintenance access

WM/WS High-Speed Wrap Around Sleeveers

Product Features

- Stainless steel construction
- Mechanical or servo motion
- Fully automatic, continuous motion design
- Multi-head rotary sleeve feeder
- Fully adjustable with screw adjustments and digital readouts for size changes
- Horizontal powered magazine
- Capable of forming lock style or glued sleeves
- Nordson® ProBlue hot melt glue system (when glue is specified)
- Allen-Bradley® PL C control system with color touch screen HMI
- Onboard performance and fault diagnostics system
- Category 3 safety system with a fully-interlocked barrier guard package
- PackML programming
- Many options available upon request

Typical Applications

- Frozen entrees
- Single pack trays, cups and bowls
- Fruit cup multi-packs
- Aseptic Beverage multi-packs
- Beverage bottle multi-packs
- Consumer products

Utilities

Electrical

230/460 VAC, 3-Phase with ground (PE), 60 Hz, 30A

Air Consumption

2-3 CFM @ 65-70 PSI

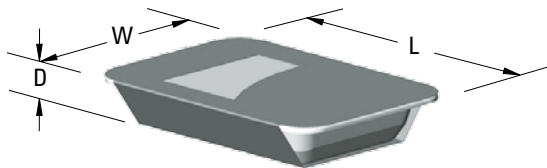

PLAN VIEW

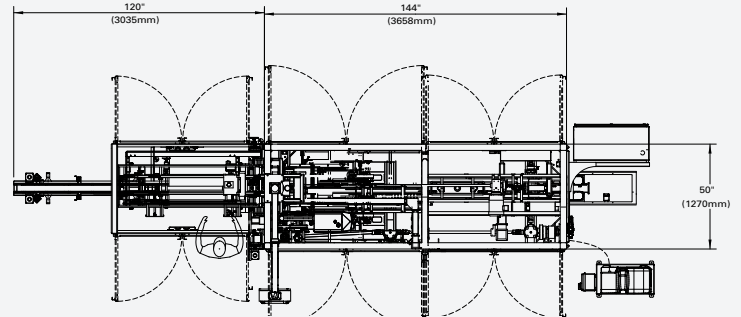

SIDE ELEVATION

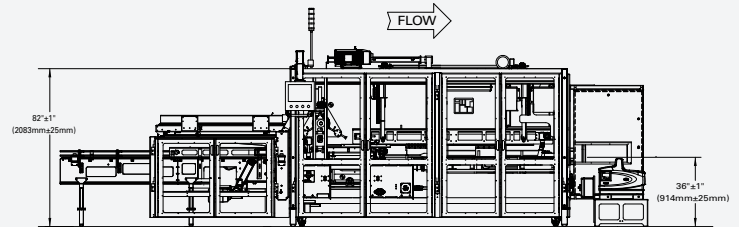

SLEEVE SIZE RANGE

Dimensions	(in)		(mm)	
	Min	Max	Min	Max
Length	Consult Factory			
Width	Consult Factory			
Depth	Consult Factory			



For more information on this product, scan the QR code with your mobile device.